

# INSTALLATION INSTRUCTIONS

## Integrated LED Architectural Pendant



|   |                                      |   |
|---|--------------------------------------|---|
| <p><b>COMPLETE WIRING DIAGRAM:</b></p>  | <p><b>Tools Required:</b></p>        |   |
|   | <p>1. Drill with 7/32" drill bit</p> | <p>2. Hacksaw</p>                               |
| <p>3. 2.5mm Hex Key / Allen Wrench</p>  | <p>4. Wire Snip</p>                  | <p>5. Screw driver</p>                          |
| <p><b>IMPORTANT SAFETY INSTRUCTIONS</b></p> <p>When installing or using this luminaire, basic safety precautions should always be followed including the following:</p> <ol style="list-style-type: none"> <li>1. Read all instructions before attempting to install this product.</li> <li>2. Ensure main power is off before installing or wiring this luminaire.</li> <li>3. This product must be installed in accordance with the applicable NEC and local codes by a person familiar with the construction and operation of the product and the hazards involved.</li> <li>4. Disconnect electrical power before adding to or changing the configuration of this product.</li> <li>5. Save these installation instructions and refer to them when modifications are made.</li> <li>6. Failure to follow safety instructions will void warranty.</li> <li>7. Two or more assemblers recommended.</li> </ol> |                                      |   |
| <p><b>Aircraft cable suspension installation video</b></p>  |                                      | <p><b>Rod suspension Installation video</b></p> |

# INSTALLATION INSTRUCTIONS

## Integrated LED Architectural Pendant



### FIXTURE

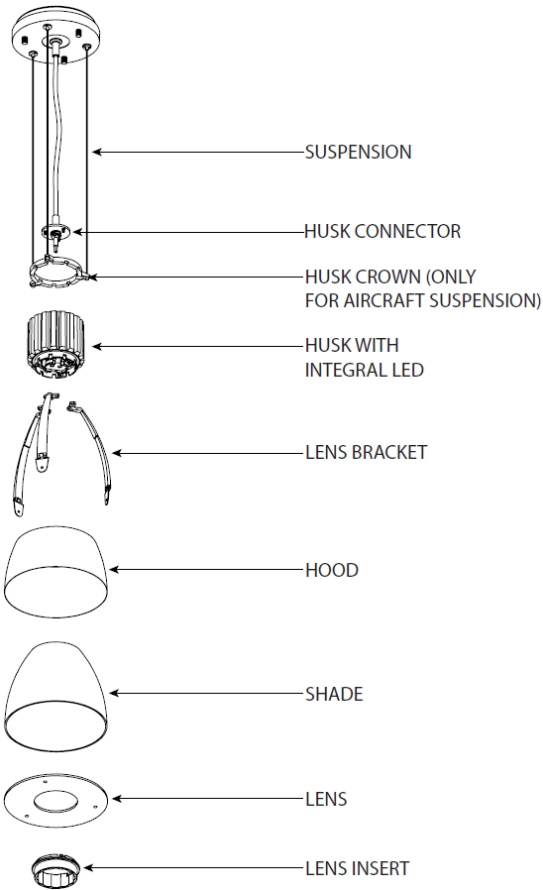

### SUSPENSION MODIFICATION & INSTALLATION

#### Rod Suspension Modification

1. Take consideration of the canopy and the fixture measurements before making any suspension modification.\*
2. Pull wires out of rod(s).
3. Remove the pivot ball with a hex key (Fig A).
4. Use hacksaw to cut the upper rod (rod with holes in one end, where the pivot ball was removed from) to desired length and discard end with holes (Fig B). Note: if only using the lower rod for hanging, cut the side of the rod with threads, not the husk connector.
5. Insert cut side of rod completely into pivot ball.
6. USING THE NON-THREADED PILOT HOLE AS A JIG (Fig C), drill hole through the rod or drill from each side. (7/32" drill bit needed)
7. Feed wires through rod(s).
8. If using both rods, connect the upper and lower rods using the threaded part. ENSURE THE UPPER AND LOWER ROD IS TIGHTLY SECURED (Fig D).
9. Remove metal plate with driver to feed rod through canopy and connect pivot ball to rod using the set screw, reattach metal plate. Set screws should thread through the new holes in the rod. ENSURE THE SET SCREW HOLDS THE PIVOT BALL IN PLACE (Fig E).

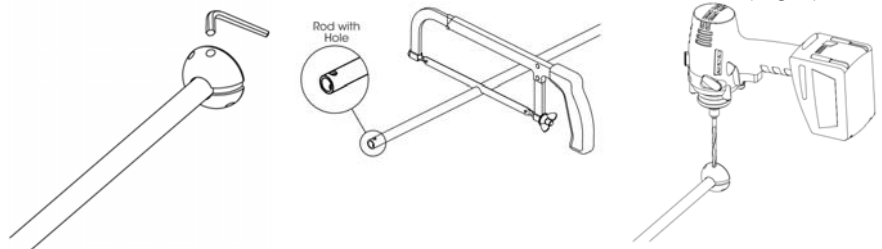

Fig A

Fig B

Fig C



Fig D

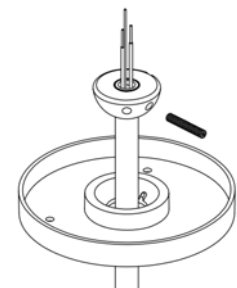

Fig E

\*Accurate measurements listed on the product specification sheet

†lens bracket, hood, lens, and lens insert are accessories

# INSTALLATION INSTRUCTIONS

## Integrated LED Architectural Pendant



### Cord & Aircraft Cable Suspension

1. Cut ground wire near cord to reattach to newly cut cord later (Fig F).
2. If cutting electrical cord, undo strain relief on bottom of husk attachment (Fig F).
3. Move up husk attachment to move out of the way.
4. Cut cord to desired length (leave a bit extra for stripping). Strip ends of wires (Fig G)
5. Re-position husk attachment and reattach strain relief. Note: the strain relief must be positioned on the outer jacket of the cord for proper placement (Fig G).
6. Connect the ground wire cut in step 2 to the green wire from the newly cut cord (Fig G).
7. The aircraft cables **MUST** support the weight of the fixture. There should be no tension on the electrical cord running through the center (it must be slack).
8. To adjust aircraft cable at the canopy, push cable in to shorten or push in cable locking sleeve to release the cable down to lengthen (Fig H).
9. If shortening the aircraft cables, unscrew the screws, cut the extra aircraft cable hanging with a snip or shear and make a loop to reattach the screws as it was initially installed (Fig I)



Fig F



Fig G

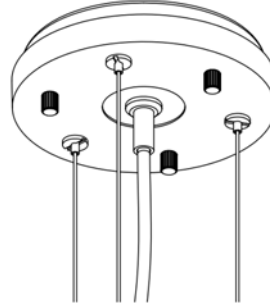

Fig H

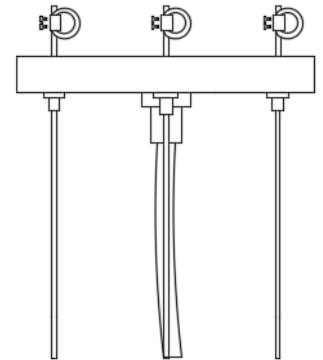

Fig I

### **PENDANT ASSEMBLY & INSTALLATION**

1. If using aircraft cable suspension, install husk onto crown first (Fig J).
2. If using lens bracket, attach to husk using supplied screws. Align bracket to notch on cable suspension crown when used (Fig K and Fig L).
3. If using hood, slide hood over refractor/ diffuser before mounting to husk (Fig M).
4. Secure reflector/ refractor/ diffuser to husk using supplied plate & nuts (Fig N).

Fig J

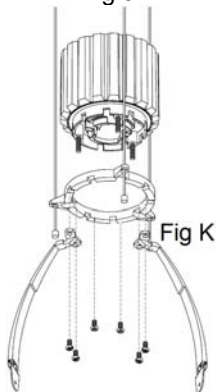

Fig K

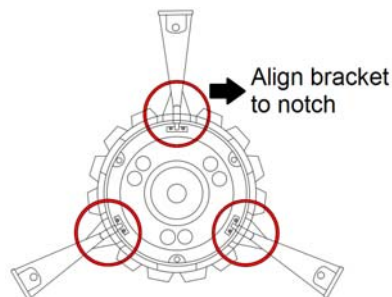

Fig L

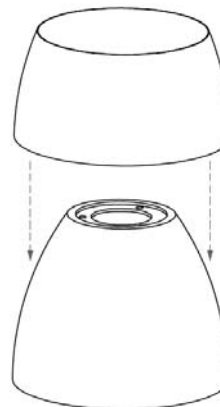

Fig M

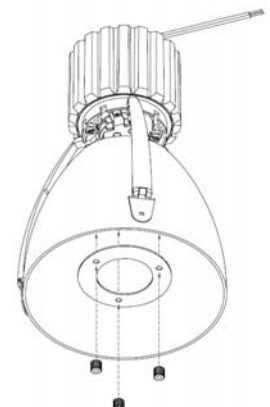

Fig N

# INSTALLATION INSTRUCTIONS

## Integrated LED Architectural Pendant



5. If using lens, mount to lens bracket & attach using supplied thumb screws (Fig O).
6. Connect white wire from the suspension to the red wire from the Husk, black wire to black wire (the green wire is already grounded, if not than green wire to green wire) (Fig P).
7. Attach suspension system to husk using supplied screws (Fig Q). (If using rod suspension, feed rod through canopy first).

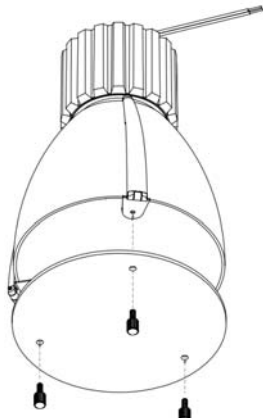

Fig O

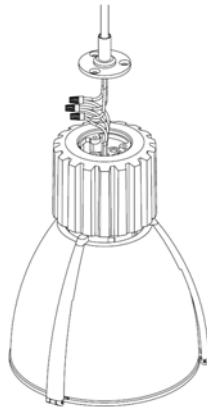

Fig P

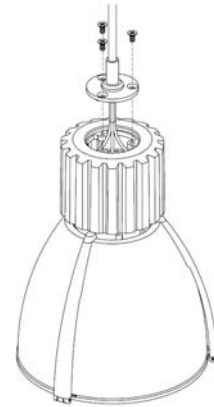

Fig Q

### CANOPY INSTALLATION

1. Turn off power at the fuse or circuit breaker panel.
2. Route wires from the J-Box through the mounting plate (Fig R).
3. Attach mounting plate to J-Box (Fig R).
4. Connect black input wire from driver to hot from J-Box, white wire to neutral and green wire to ground. (Driver input connected to J-Box, driver output connected to suspension. Shown in Complete wiring diagram, Page 1).
5. If using rod suspension, detach metal plate with driver to feed rod through canopy from pivot side and attach RED output driver wire to the WHITE wire from the suspension, BLACK wire to BLACK wire and GREEN wire to GREEN or bare lead wire. Reattach the metal plate with the driver
6. If using aircraft cable suspension system, the aircraft cables MUST support the weight of the fixture. There should be no tension on the electrical cord running through the center (it must be slack).
7. Securely mount canopy cover to mounting plate using supplied canopy nuts (Fig S).

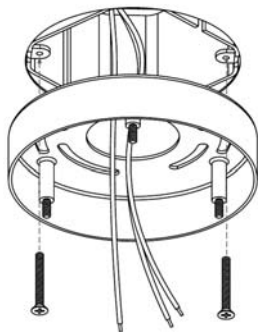

Fig R

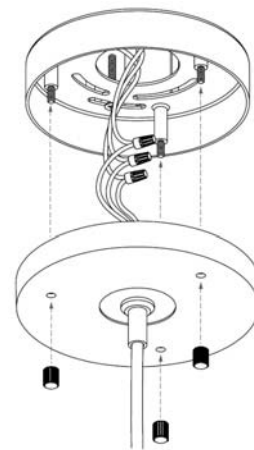

Fig S